

pco.dicam C1

intensified 16 bit **sCMOS** camera

intensified
sCMOS

enhanced
extinction ratio gating

104 fps
@ full resolution



intensified
sCMOS technology
2048 x 2048 pixel

exposure time 4 ns
with 25 mm intensifier

with
CAMERA
LinkHS
interface

pco.



pco.dicam C1

After 30 years of continuous success in development and production of intensified cameras, **PCO** introduces the new pco.dicam C1 - the first intensified camera system which exploits the full performance inherent to **scientific CMOS** sensor technology.

It is the optical coupling of 25 mm high resolution image intensifiers with an outstanding high efficiency tandem lens system to a 16 bit 4 Mpixel **sCMOS** sensor which makes the camera so unique. Camera Link HS, the latest standard of high performance data interfaces for scientific cameras, guarantees uncompressed and robust 16 bit data transfer of 104 full frames per second via optical fiber over virtually any distance.

& feature benefit

104 frames/s @ full 4.2 Mpixel resolution	high frame rates at high resolution for imaging of dynamic processes
> 1000 frames/s @ reduced resolution	kHz scan rates for spectroscopic applications
1.1 e⁻ readout noise	lowest readout noise of any gated intensified camera system
16 bit digitization	taking advantage of the higher dynamic range possible from high end image intensifiers
25 mm high resolution image intensifier	doubles the optical resolution of conventional 18 mm image intensifiers
optical coupling via ultra-speed tandem lens	outstanding image quality with high transmission efficiency and no artifacts
tandem lens with 0.53 : 1 image scaling	full 25 mm diameter of intensifier output is lossless imaged onto sCMOS sensor
fiber based Camera Link HS data interface	fiber optical interface virtually covers any distance without deploying additional interface converters or signal amplifiers with immunity to EMI
870 MByte/s image data rate	highest sustained image data rate of any intensified camera system on the market; no limitations for recording duration
double shutter mode with 500 ns interframing time	two consecutive full resolution images with a configurable minimum interframing time of 500 ns
4.2 MPix sCMOS sensor	overcomes CCD limitations in terms of speed and sensitivity
enhanced extinction ratio gating	fast MCP gating for improved extinction ratio for the blue and uv part of the spectrum
additional optical trigger input	robust trigger transmission over long distance in EMC critical environments
EF lens control	convenient remote lens control for camera systems inaccessible during an experiment
selected highly homogeneous image intensifiers	integrated best image intensifier quality available on the market
45 ns trigger to exposure start delay	ultra fast camera reaction to trigger event
4 ns gating with 25 mm intensifier	captures fast transient phenomena
extensive and highly precise IN/OUT signaling	allows for perfect synchronization in any experimental set-up as timing master or slave
configurable delay in steps of 1 ns	flexible adaptation to synchronization needs

» applications

laser induced incandescence (LII) | shock wave physics | laser induced breakdown spectroscopy (LIBS) | particle image velocimetry (PIV) | time resolved spectroscopy | plasmaphysics | laser induced fluorescence (LIF) | ballistics | combustion

camera modules

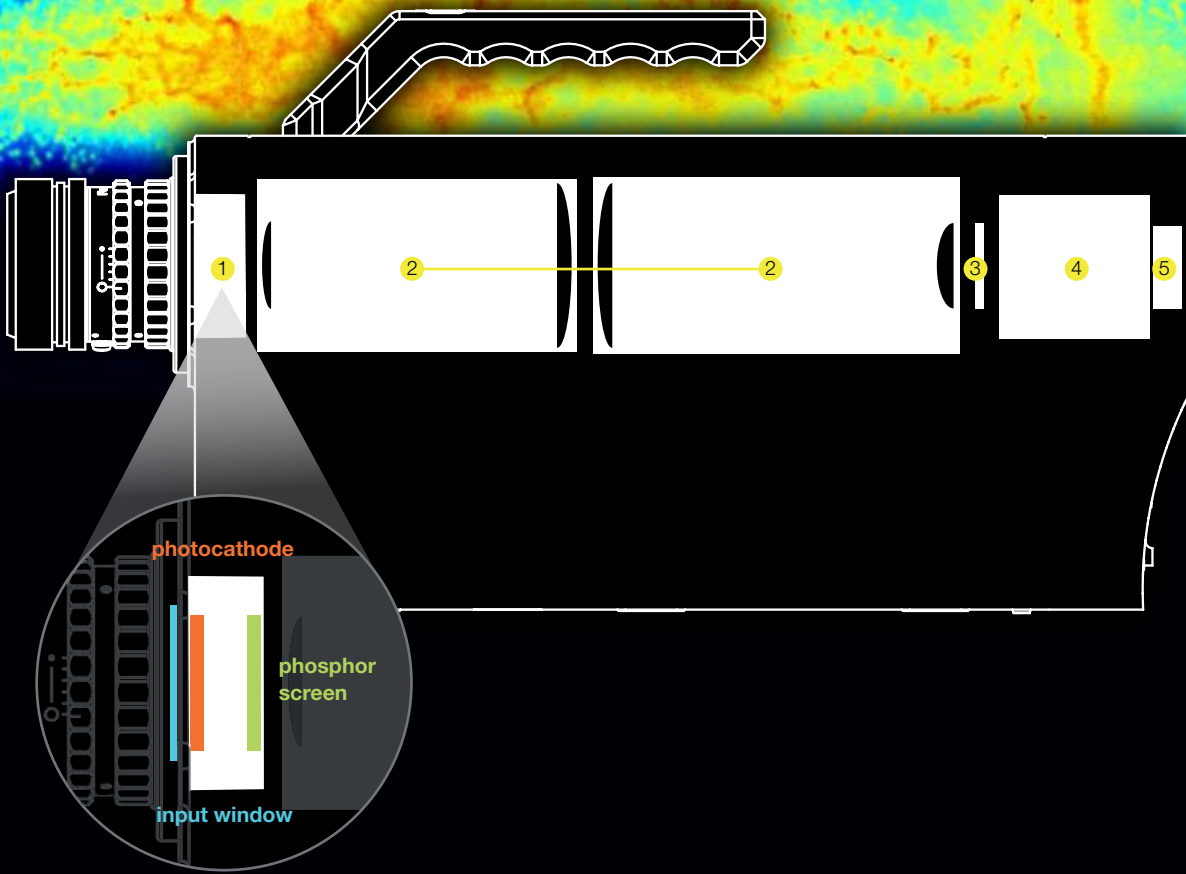

	page
① image intensifier	6 - 7
② optical coupling lens system	8
③ sCMOS image sensor	4
④ camera system	5
⑤ CLHS interface	8

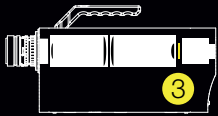

» sCMOS image sensor

type of sensor	scientific CMOS (sCMOS)
resolution (h x v)	2048 x 2048 active pixel
pixel size (h x v)	6.5 μm x 6.5 μm
sensor format / diagonal	13.3 mm x 13.3 mm / 18.8 mm
shutter mode	single image double image
MTF ¹	76.9 lp/mm (theoretical)
fullwell capacity	15 000 e ⁻
readout noise ²	1.1 med / 1.5 rms e ⁻ single image 2.2 med / 2.5 rms e ⁻ double image
dynamic range	13 600 : 1 (82.7 dB)
quantum efficiency	58 % for P43 peak emission @ 545 nm 57 % for P46 peak emission @ 530 nm
spectral range	370 nm ... 1100 nm
dark current ³	< 0.6 e ⁻ /pixel/s @ 7 °C
DSNU	1.0 rms e ⁻
PRNU	< 0.6 %
anti blooming factor	1 : 10 000

» quantum efficiency

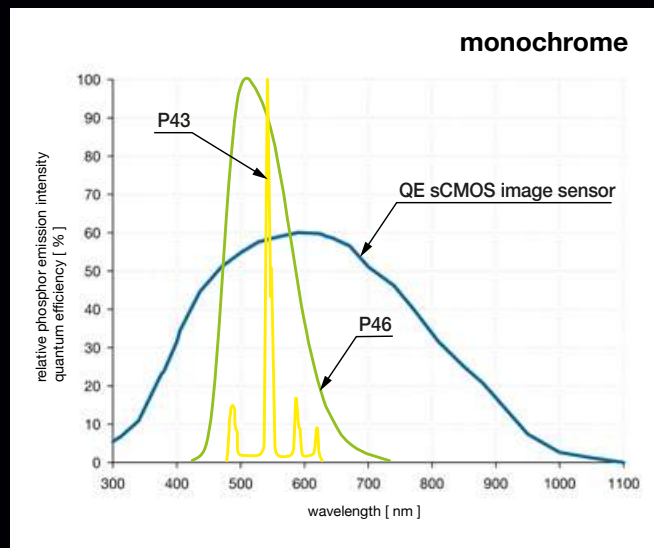

» frame rate table

2048 x 2048	up to 104 fps
2048 x 256	up to 830 fps
line scan mode	> 1000 fps

¹ Modulation transfer function

² The readout noise values are given as median (med) and root mean square (rms) values due to the different noise models, which can be used for evaluation. All values are raw data without any filtering.

³ Measurements with dark current compensation



» camera system

frame rate	up to 104 fps @ 2048 x 2048 pixel
dynamic range A/D⁴	16 bit
pixel scan rate	286.0 MHz
binning horizontal	x1, x2, x4
binning vertical	x1, x2, x4
region of interest (ROI)	horizontal: steps of 4 pixels vertical: steps of 1 pixel
non-linearity	< 1 %
cooling method	+7 °C stabilized, 1 stage peltier with forced air (fan)
input signals	optical trigger (FOL), electrical trigger, arm input (TTL level, BNC connectors), gate disable (high-speed TTL input, BNC connectors)
output signals	gate/expos out monitor, user monitor output (TTL level, BNC connectors)
data interface	Camera Link HS (Single F2, 1X1, S10)
time stamp	in image (1 µs resolution)

» exposure modes

single image mode	
exposure times	4, 10 ns fixed, 20 ns ... 250 ns (1 ns steps), 250 ns ... 1 s (10 ns steps)
delay times	0 ns ... 250 ns (1 ns steps), 250 ns ... 1 s (10 ns steps)
maximum repetition frequency	> 1 kHz
insertion delay (trigger input - shutter)	< 50 ns
jitter	< 1 ns
double image mode	
exposure times	20 ns ... 1 s (in 10 ns steps)
delay settings	0 ns ... 1 s (in 10 ns steps)
minimum interframing time	500 ns ... 10 ms (in 10 ns steps)

» general

power supply	18 ... 28 VDC
power consumption	35 ... 40 W
weight	7 kg
operating temperature	+ 10 °C ... + 40 °C
operating humidity range	10 % ... 80 % (non-condensing)
storage temperature range	- 10 °C ... + 60 °C
optical interface	F-mount & C-mount or special mounts (Canon mount)
lens remote controller	electronic control for Canon EF lenses
CE / FCC certified	yes

⁴ The high dynamic signal is simultaneously converted at high and low gain by two 11 bit A/D converters and the two 11 bit values are sophisticatedly merged into one 16 bit value.

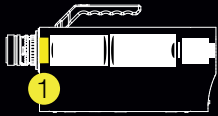

» image intensifier

type	HighRes MCP ⁵ (6 μm channel)
input window	synthetic silica, borosilicate (MgF ₂ optional)
photocathode material	S20, GaAs, GaAsP (others on request)
image intensifier	6 μm
pitch distance	
image intensifier MCP type	single stage low resistance MCP for high strip current
MCP operational modes	continuous gated for enhanced extinction ratio
image intensifier diameter	25 mm (18 mm optional on request)
phosphor screen material	P43, P46
output window	glass
image intensifier system resolution	> 50 lp/mm @ 5 % MTF typical (depends on phosphor)
shortest gating time	4 ns

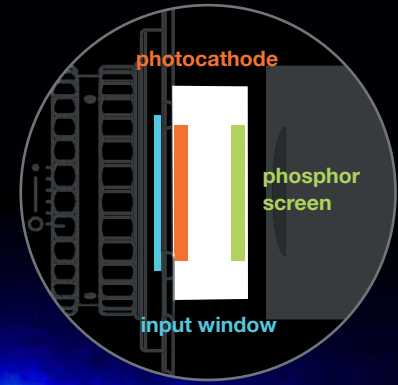

» image intensifier input window

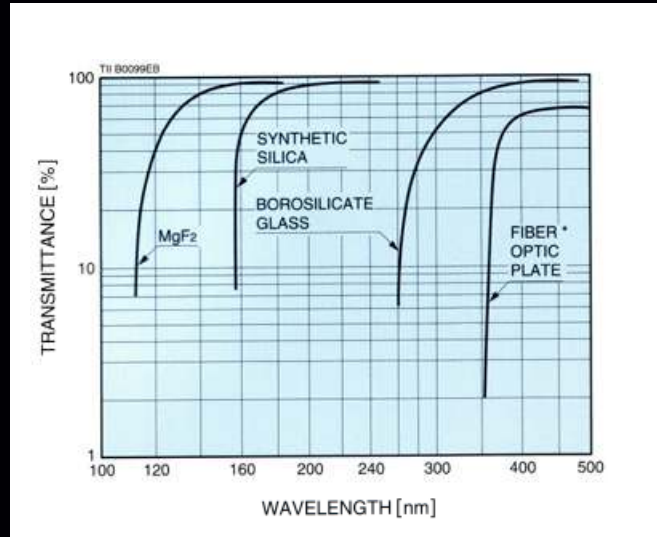

Typical transmittance of image intensifier input window materials

To make use of the good UV-sensitivity of S20 photocathode material the standard input window is made of synthetic silica for transmission down to 180 nm.

GaAs and GaAsP photocathodes are deposited on borosilicate glass.

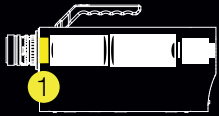

» image intensifier photocathode characteristics

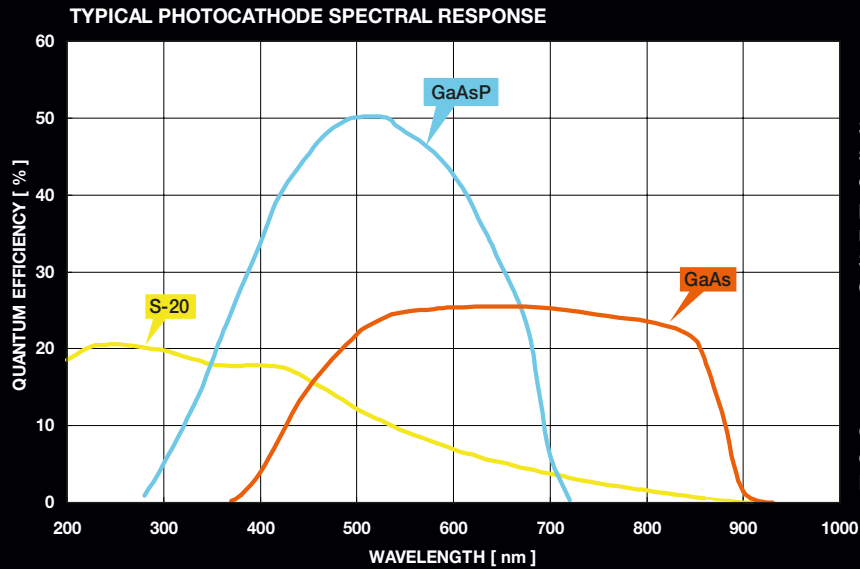

Spectral sensitivities of different photocathode materials: S20 (multialkali), GaAs, GaAsP

data courtesy of Hamamatsu Photonics

photocathode material	peak wavelength [nm]	quantum efficiency at peak wavelength [%]	equivalent background input (EBI) [W/cm ²]	dark counts [s ⁻¹ /cm ²]
S20 (multialkali)	430	14 .. 18	3·10 ⁻¹⁴	1500
GaAs	530 - 750	23	3·10 ⁻¹⁴	30 000
GaAsP	480 - 530	50	3·10 ⁻¹⁴	10 000

data courtesy of Hamamatsu Photonics

» image intensifier phosphor

phosphor	phosphor decay (typ.) to..		peak emission	typical efficiency
	.. 10%	.. 1 %		
P43	1 ms	4 ms	545 nm	100 %
P46	0.2 - 0.4 μs	2 μs	530 nm	30 %

All photocathode materials can be combined with P43 or P46 phosphor. Whereas the P43 phosphor has a much brighter emission than the P46 phosphor, it has a rather long decay time, i.e. the time required till the phosphor emission fades out after the excitation by electron bombardment has been stopped. This decay time is therefore critical for fast image repetition rates primarily in double image application or when operating the camera in spectroscopic mode with line rates in the kHz range.

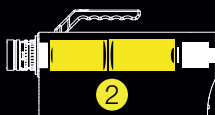

» optical coupling lens system

“ultra-speed tandem lens” between image intensifier & sCMOS

transmission efficiency	> 30 %
vignetting	< 3 %
resolution	> 60 lp/mm
scaling rates	$\beta=0.53$ for 25 mm intensifier

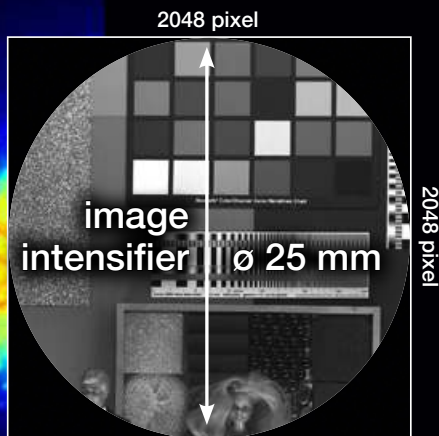

The projected image circle is completely covered by 2048 x 2048 6.5 μm pixels of the sCMOS detector – cf. image left. There is no “waste” of valuable intensifier area. As a consequence the four corners of the sCMOS sensor remain black. For a fast scan of just a few vertically centered lines – the camera module allows for more than 1.000 fps for such a ROI - the full line length of 2048 pixels is available.

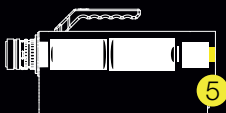

» camera interface



data transfer	Camera Link HS, FOL cable, frame grabber
input signals	optical trigger (FOL), electrical trigger, arm input (TTL level, BNC connectors), gate disable (high-speed TTL input, BNC connectors)
output signals	gate/expos out monitor, user monitor output (TTL level, BNC connectors)

» software

Camware is provided for camera control, image acquisition and archiving of images in various file formats (Windows 7 and later). A free software development kit (SDK) including a dynamic link library for user customization and integration on PC platforms is available. Drivers for popular third party software packages are also available. (www.pco.de)

pco.dicam C1

» lens remote controller

The optional Canon lens control adapter enables the user to connect electronic EF- and EF-S Canon lenses allowing to remote control focus and aperture of those lenses.



» dimensions

F-mount and C-mount lens changeable adapter.

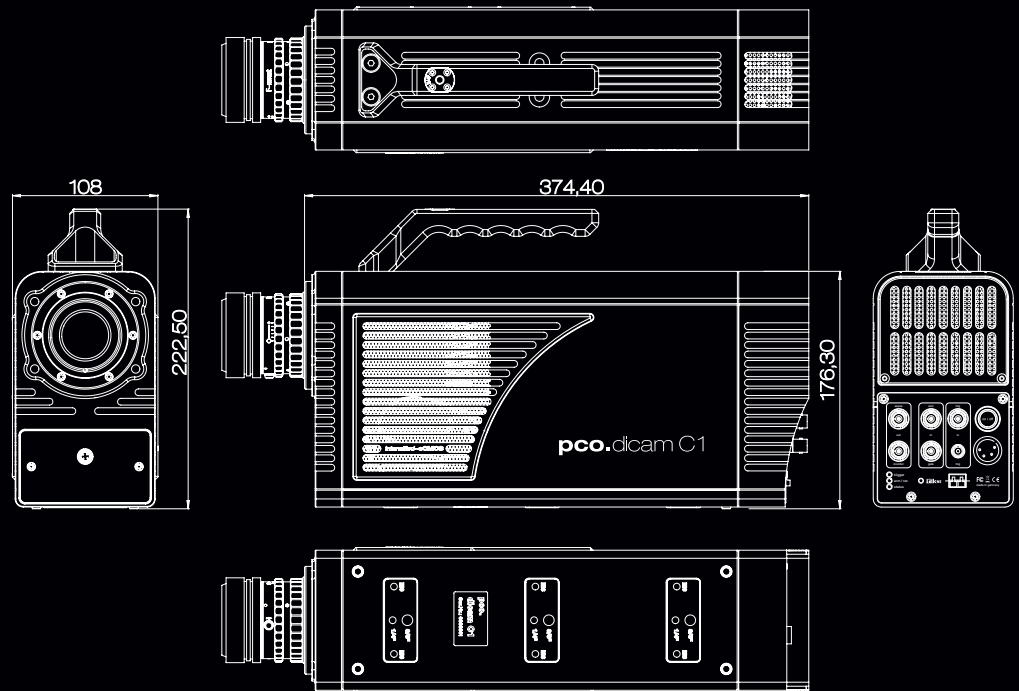

All dimensions are given in millimeter.

» camera view



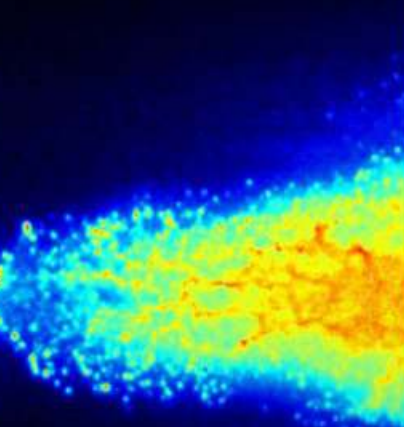

» photocathode	input window	phosphor	select
S20 selected*	synthetic silica	P46	<input type="checkbox"/>
		P43	<input type="checkbox"/>
GaAs standard*	borosilicate	P46	<input type="checkbox"/>
		P43	<input type="checkbox"/>
GaAs selected*	borosilicate	P46	<input type="checkbox"/>
		P43	<input type="checkbox"/>
GaAsP standard*	borosilicate	P46	<input type="checkbox"/>
		P43	<input type="checkbox"/>
GaAsP selected*	borosilicate	P46	<input type="checkbox"/>
		P43	<input type="checkbox"/>

* image intensifiers with GaAs and GaAsP photocathode are available in two quality grades:
 standard: quality specified for central 16 mm x 16 mm square region corresponding to 1300 x 1300 pixel sCMOS sensor resolution
 selected: quality specified for 24.9 mm diameter area corresponding to full 2048 x 2048 pixel sCMOS sensor resolution,
 extinction ratio 10 times higher than standard grade
 image intensifiers with S20 photocathode exclusively come in selected grade quality
 contact our technical sales team for further details on the two quality grades

» optical interface	select
C-mount	<input type="checkbox"/>
F-mount	<input type="checkbox"/>
EF lens control	<input type="checkbox"/>

» FOL	select
type of data interface FOL module in camera and frame grabber	
SM SFP+ up to 10 km	<input type="checkbox"/>
MM SFP+ up to 300 m	<input type="checkbox"/>

FOL cable length default: 10 m

**contact us for any help
or expert consultation
regarding your needs**

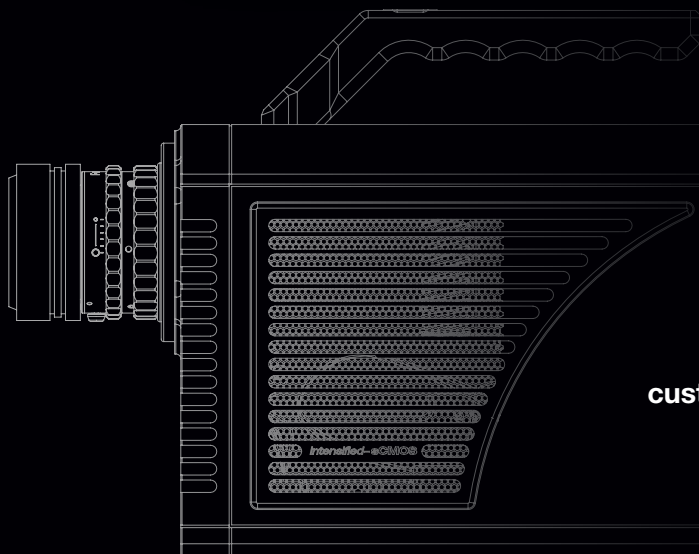

customize your **pco.dicam C1**

find us

europe

PCO AG
Donaupark 11
93309 Kelheim, Germany

+49 9441 2005 50
info@pco.de
pco.de



america

PCO-TECH Inc.
6930 Metroplex Drive
Romulus, Michigan 48174, USA

+1 248 276 8820
info@pco-tech.com
pco-tech.com

asia

PCO Imaging Asia Pte.
3 Temasek Ave
Centennial Tower, Level 34
Singapore, 039190

+65 6549 7054
info@pco-imaging.com
pco-imaging.com



china

Suzhou PCO Imaging Technology Co., Ltd.
Suzhou (Jiangsu), P. R. China

+86 512 67634643
info@pco.cn
pco.cn



for application stories
please visit our website

