

AuraTek-Square

Next generation Multi-Anode MCP-PMT

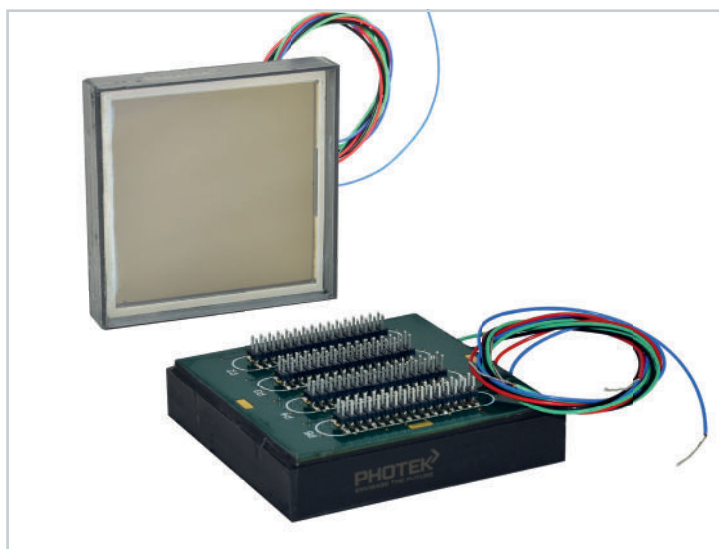

The AuraTek-Square is a next generation Multi-Anode Micro-Channel Plate Photo-Multiplier Tube (MCP-PMT). It can be configured as a multi-channel single photon counter or analog photon pulse analyzer.

The AuraTek-Square has an active area of 53 mm x 53 mm with packaged anode configurations of 32 x 32 with 1.656mm pitch, 16 x 16 with 3.312mm pitch, and 8 x 8 with 6.624mm pitch. A non packaged version with anode configuration of 64 x 64 with 0.828mm pitch is also available. Custom readout configurations with different anode pitch and signal connectors can be considered. The square tube format enables efficient tiling of multiple AuraTek-Squares to cover large areas.

The timing performance is state-of-the-art, with pulse rise-time of 330 ps and single photon transit time spread (TTS) of < 40 ps rms per channel using the standard 15 micron pore MCPs, and < 25 ps TTS (figure 2) using optional 6 micron pore MCPs.

Integrated photon counting electronics are also optionally available, whilst preserving the tileable format. Ask our experts to help you select the best readout electronics for your application.

Key Attributes

- > True noiseless photon counting
- > < 860 ps FWHM pulse width
- > Transit time spread of < 40 ps rms
- > Extremely low dark counts
- > Highest anode density of any PMT with 0.828mm pitch and 4096 anodes
- > Variety of high QE, low noise photocathodes covering full UV to visible wavelengths
- > Long lifetime MCPs with enhanced collection efficiency
- > Immunity to magnetic fields
- > Assistance with selection of optimal readout electronics

Applications

- > Ring Imaging Cherenkov (RICH)
- > Detection of Internally Reflected Cherenkov (DIRC)
- > Sampling Calorimeter Readout
- > Wavelength Shifting Fibre Readout
- > Scintillating/Cherenkov Fibre Readout
- > Beam Monitor
- > High Content Screening
- > Time Resolved Spectroscopy
- > LiDAR
- > Standoff Chemical/Biological Detection
- > Microplate Readout

Product Overview

General Characteristics	
Window	Fused Silica (Optional Fibre Optic/Sapphire)
Active Area	53 x 53 mm
Electron Multiplier	Dual MCP
Anode Formats	64 x 64 on 0.828 mm pitch
	32 x 32 on 1.656 mm pitch
	16 x 16 on 3.312 mm pitch
	8 x 8 on 6.624 mm pitch
Photocathode	Solar Blind, Bi-Alkali, S20, S25

Specifications

Single Photon Response (typical)	15 um MCP	6 um MCP
Pulse Risetime (10% to 90%)	330 ps	300 ps
Pulse Width	860 ps FWHM	800 ps FWHM
Transit Time Spread	< 40 ps RMS	< 25 ps RMS
Pulse Height Distribution	100% FWHM	100% FWHM
Linear Total Count Rate	Up to 10 MHz	Up to 10 MHz

Maximum Ratings	
Overall Voltage	< 3500 V
Operating Temperature	-50°C to +50°C
Storage Temperature	-50°C to +50°C

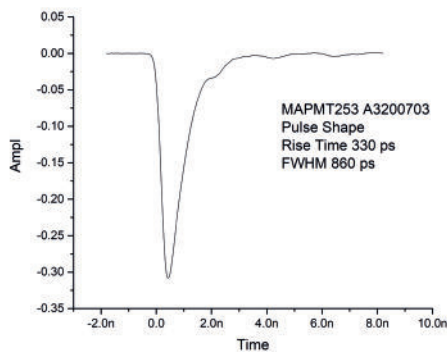

Figure 3 : Typical risetime of AuraTek-Square with 15 um MCPs.

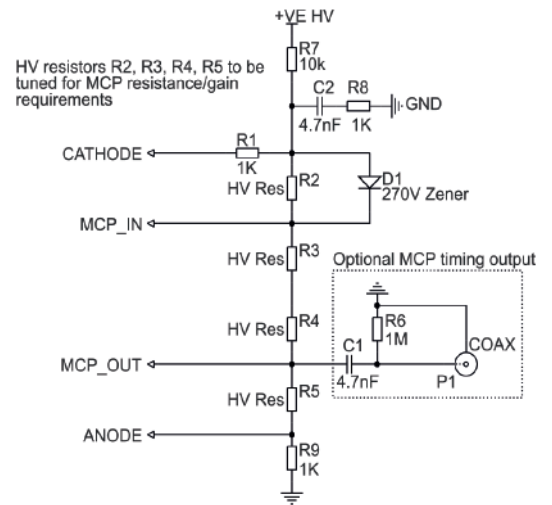

Figure 1 : Typical dropper chain example

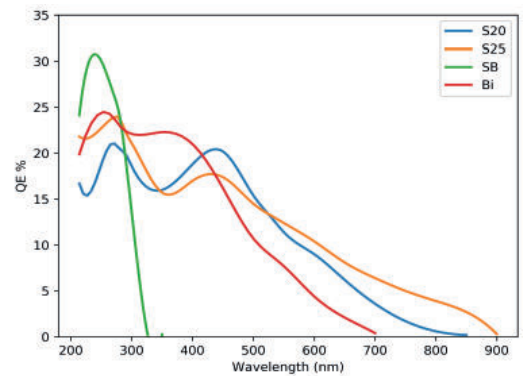

Figure 2 : Available photocathodes on fused silica window. Optional fibre optic window will reduce sensitivity and no response below 300 nm.

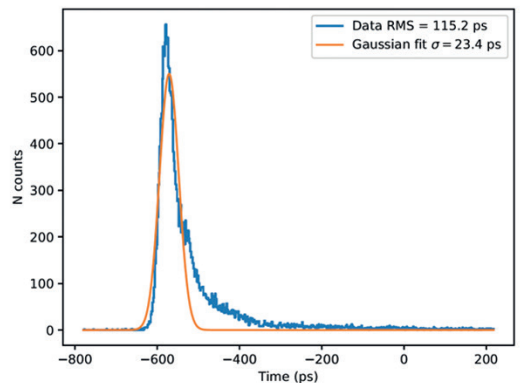
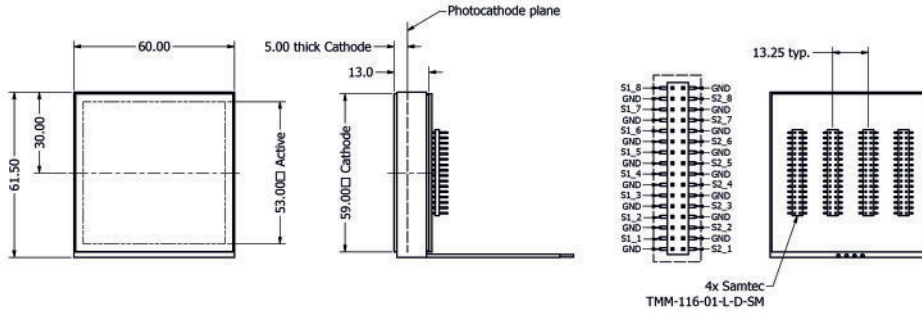

Figure 4 : Transit time spread of an AuraTek-Square with 6 um MCPs in response to a picosecond laser source.

Outline Drawings

8x8 ANODE CONFIGURATION



16x16 ANODE CONFIGURATION

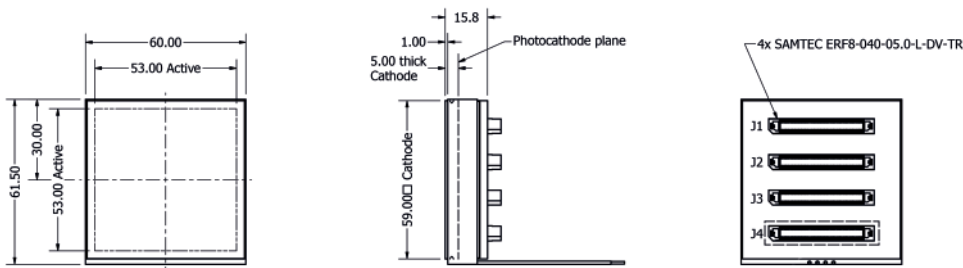

32x32 ANODE CONFIGURATION

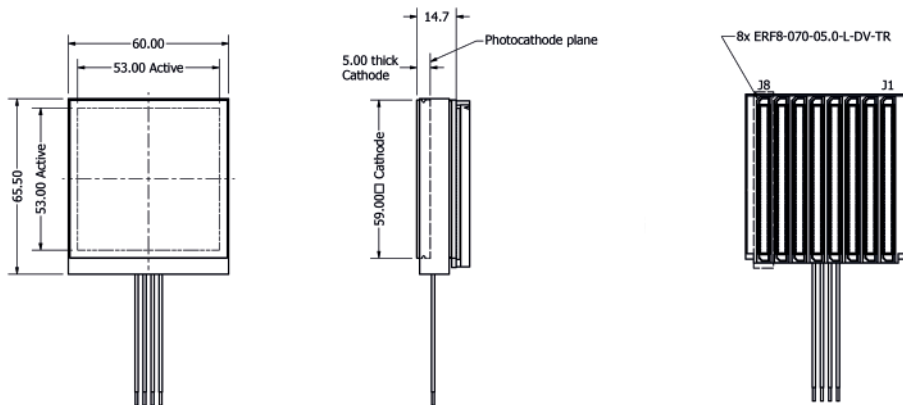

64x64 ANODE CONFIGURATION (non-packaged)

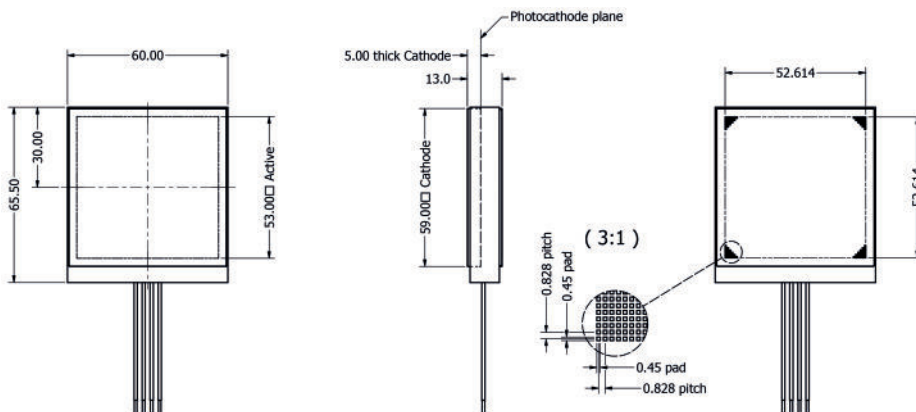

About Photek

Photek is a specialist manufacturer of vacuum based tubes and camera systems for photon detection.

Our product range includes; Camera Systems, Image Intensifiers, Photomultiplier Tubes, Streak Tubes plus a range of associated electronics.

We are experts in large area and ultra-high speed imaging and advanced photon counting camera systems.

Our continuing success is built upon continuous innovation and product development, and by harnessing and applying knowledge to find solutions for all of our customers' applications.

Photek is accredited to ISO 9001 and ISO 14001.



Contact Us

Our team of specialist engineers and scientists are ready to discuss your application requirements in depth.

T: +44 (0)1424 850 555

E: sales@photek.co.uk

Photek Ltd reserves the right to update and improve this document without prior notice.