

HRPCS

High Resolution Photon Counting System



The HRPCS5, now in its 5th generation, is a true single photon counting camera providing the ability to capture and integrate ultra-low-light images in real time.

The HRPCS5 is a parallel readout device capable of detecting multiple photons at the exactly the same time. Its readout rate of 50 frames per second at full resolution, low dark count rate 1.3 Mpix sensor provides high sensitivity over a wide dynamic range.

Bespoke versions of the HRPCS5 can be delivered with any of the wide range of Photek's image intensifiers. Full systems can be provided with sensor cooling for ultra low noise, computer controlled sample stage, sample temperature control and light-tight enclosures.

Operation has never been easier thanks to the plug-n-play USB 3.0 interface and intuitive Image32 software that includes functions specifically designed for photon counting applications.

Key Attributes

- > 50 full frames per second
- > 1.3 megapixel readout
- > Variety of high QE, low noise photocathodes covering the full UV-VIS band
- > Bright field mode for focusing
- > Integrated optical gating
- > Fibre optic input for proximity focus
- > USB 3.0 interface
- > Easy to use software with functions specifically designed for photon counting
- > Custom options available

Applications

- > Bioluminescence Imaging of Luciferase and Aequorin
- > Chemiluminescence Imaging
- > ATP-Bioluminescence Studies
- > Simultaneous fluorescence and luminescence imaging
- > Analysis of microtiter plates
- > Autoradiography
- > X-ray and particle photon counting
- > Low light fluorescence

Specifications





Camera	Standard	High Speed Option
Sensor	e2v EV76C560ABT	Sony IMX174
Image Format	1280 x 1024 pixels	1936 x 1216 pixels
Pixel Size	5.3 microns	5.86 microns
Frame Rate (full frame)	60 fps	166 fps
ADC	10 bits	12 bits
Interface	USB 3.0	USB 3.0
Gating	Standard	High Speed Option
Min Gate Width	50 ns	3 ns
Max Repetition Rate	10 kHz	300 kHz
Gating Control	Standard	High Speed Option
Gate Controller	HRPCS	GIC3
Delay/Width Increment	5 ns steps	1 ns steps
Internal Time Base in Asynchronous Mode	Up to 10 KHz	Up to 300 KHz
Trigger Mode	External / Camera / Time base	External / Camera / Time base
Camera Trigger	Synchronous (1 gate trigger per camera frame) / Asynchronous (multiplegate triggers per camera frame)	
Intensifier	Standard	High Speed Option
Intensifier	MCP218 or MCP225	MCP218 or MCP225
Input Window Material	Fused Silica or Fibre Optic	Fused Silica or Fibre Optic
Photocathode	SB, Bialkali, S20, S25	SB, Bialkali, S20, S25
Resolution	25 lp/mm	25 lp/mm
Gain	Fully adjustable	Fully adjustable
Uniformity	10% SD/mean	10% SD/mean
Phosphor (Decay time)	P43 (1 ms to 10%) or P46 (300 ns to 10%)	P43 (1 ms to 10%) or P46 (300 ns to 10%)
Coupling Method	Fiber Optic Taper	Relay Lens
Effective Pixel Size (18 mm)	8.7 microns	9.3 microns
Effective Pixel Size (25 mm)	12 microns	13 microns

Features and Benefits

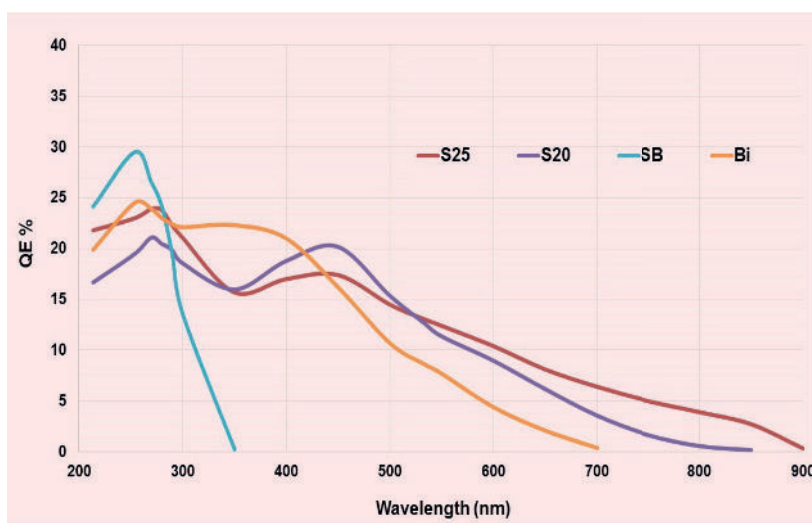
Features	Benefits
Single photon counting	Noiseless readout enhances sensitivity at very low light levels and enables long integration times
Photon location determined by integral center-of-gravity calculation	Ensures high spatial resolution in photon counting mode
Optical gating to < 3 ns	Accurately capture fast transient events while reducing unwanted background
Fibre optic coupling	Optimum coupling of the Image Intensifier to the sensor, boosting gain and reducing vignetting
Bright field mode	Simplifies camera focus
USB interface	Plug-n-play operation
Image32 software	Easy to use software specifically designed for photon counting, intensified cameras
Fully integrated gating control and power supply	No troublesome high voltage cabling
High QE image intensifiers	Best-in-class QE throughout the UV ensuring best overall signal-to-noise
Highly customizable	Options include alternative sensors, 25/40 mm image intensifiers, customized software, wide range of accessories

Quantum Efficiency Curves



Dark Count Rate at 20%		
	SB	<5
	Bi	<50
	S20	<2000
	S25	<20,000

Note: The spectral graphs shown opposite are for indication only. Detectors with Fibre Optic input windows will have lower sensitivity and no response below 300nm. If high UV response and fast gating is required, a mesh substrate is recommended. The high speed option will have lower sensitivity. Please contact the Sales office to discuss your exact requirements.

Application Examples

Luminescence dial of a watch after integrating for 700 seconds with three regions of interest highlighted.

Green curve - region of interest over the minute hand for the first several hundred seconds

Red Curve - region of interest under luminous portion of the second hand, showing signal every 60 seconds

Blue Curve - Five o'clock luminous dot showing overall intensity decrease with time after initial excitation.

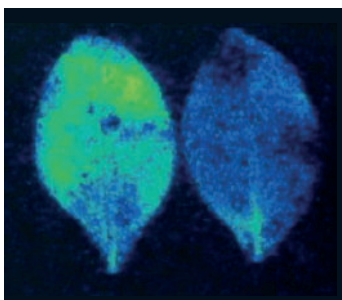
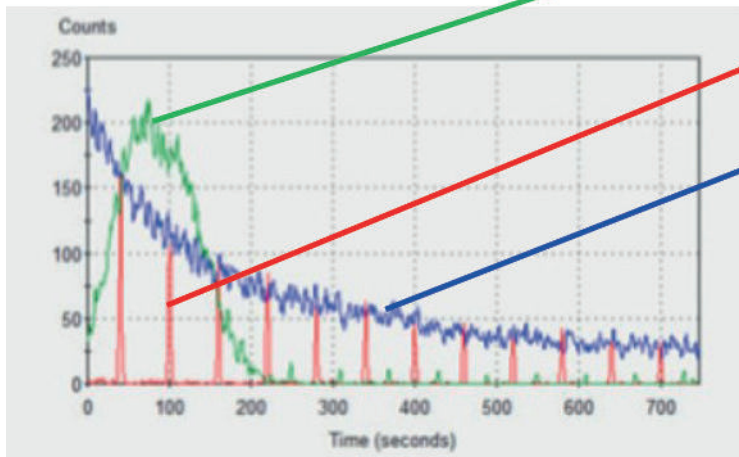
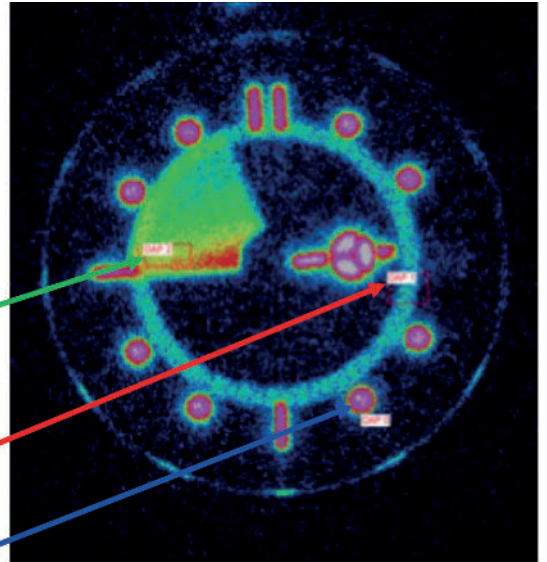

The effect of cooling roots on the leaf's free Ca²⁺

Images courtesy of A K Campbell - University of Wales, College of Medicine and School of Pharmacy

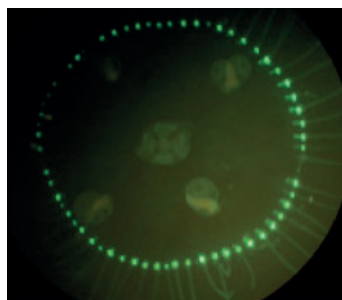

GFP fluorescence in a jelly fish, excited by blue light

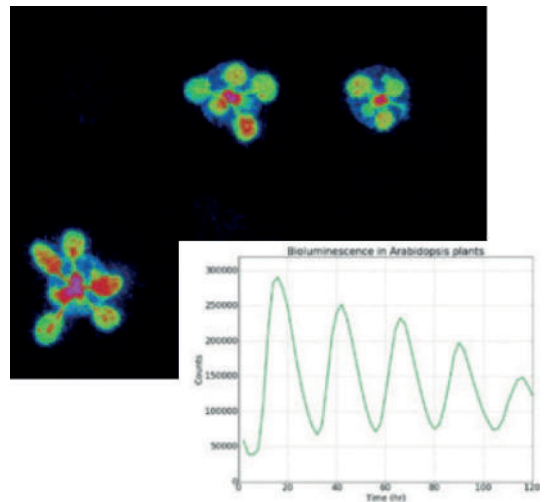

TOC1: Luciferase bioluminescence from 12 day old Arabidopsis seedlings.

Images courtesy of Antony Dodd - University of Bristol

Accumulated photons emitted from mouse eggs for a 10 minute window during an experiment that lasted several hours. The chemiluminescent light is from a luciferase fusion protein (PLCz-luciferase) that is expressed in the eggs and shown in the left image. The right image is the fluorescent light emitted during epifluorescent illumination at 490 nm of a Ca²⁺ sensitive fluorescent dye loaded into the same eggs.

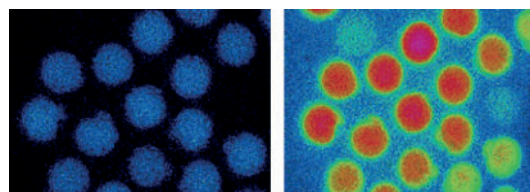

Chemiluminescence of luciferase

Fluorescence of Ca²⁺ dye

Images courtesy of K Swann - Cardiff University School of Medicine.

Photon counting scintillation imaging obtained as part of research into fungal networks

Images courtesy of Mark Fricker — Oxford University.

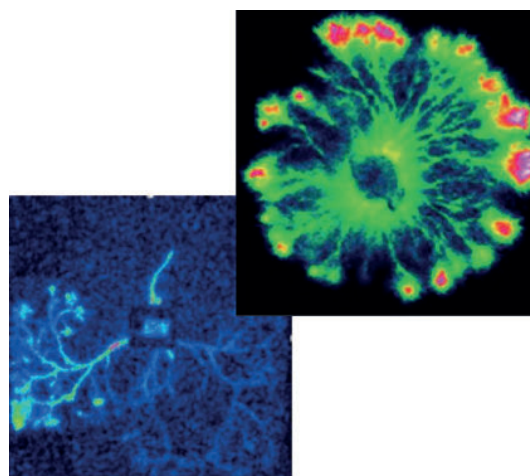

Accessories

Photek has a full range of accessories, enabling our customers to design a complete experimental set-up that works as a system straight out of the box. Contact our experts to help you design the perfect solution for your application

Component	Function
Dark Box	Light tight box with 500 mm x 500 mm working area, focus adjustment and reagent capillary tubes
Sample Stage	Image samples on a temperature controlled stage
Temperature Controller	Control cooled detector heads and sample stages
LED Light Box	Selectable LEDs to provide uniform sample illumination



Software

To harness the power of the HRPCS, Photek provides its unique and easy to use imaging software. The **Image32** image processing software provides a wide range of tools for manipulating images and analyzing data.

A simple to use dialog box for controlling the camera is provided for camera setup including: region of interest, sub sampling, exposure time, gain and recording options. Event list data including x, y photon location and time can be saved to a file for later analysis.

Included with the iCMOS 160 Camera:

AC Power Brick and mains cable, USB 3.0 Camera Cable, USB 2.0 Control Cable, Image32 Software, User Manual.



Computer Requirements		Operating Conditions	
Processor:	i5 CPU, 2 GHz minimum	Operating Temperature:	10°C to 40°C
RAM:	4 GB minimum	Relative Humidity:	<70% (non-condensing)
Operating System:	Windows 7,8,10	Storage Temperature:	0°C to 55°C
USB:	USB 3.0 port available	Power Requirements	
Min Monitor Resolution:	1024 x 768	12 V Power brick supplied, 100-240 VAC, 50-60 Hz	

Mechanical

STANDARD OPTION

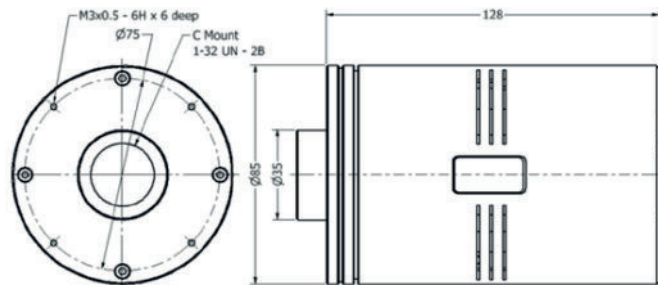

HIGH SPEED OPTION

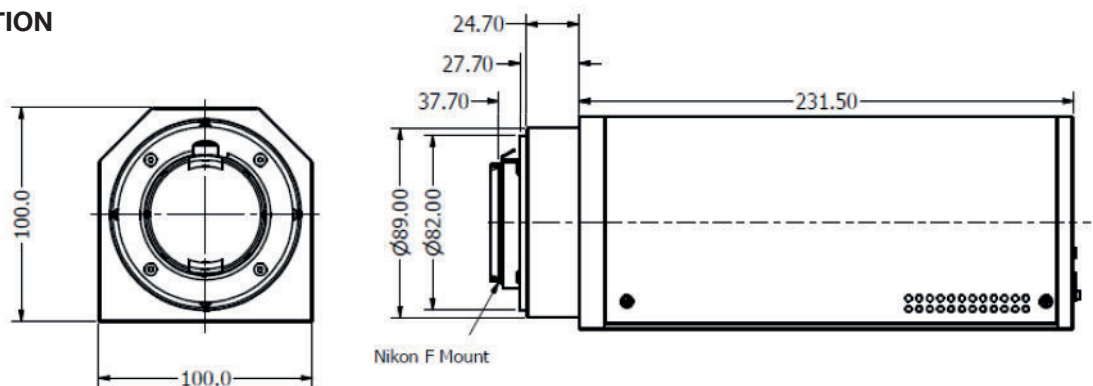

About Photek

Photek is a specialist manufacturer of vacuum based tubes and camera systems for photon detection.

Our product range includes; Camera Systems, Image Intensifiers, Photomultiplier Tubes, Streak Tubes plus a range of associated electronics.

We are experts in large area and ultra-high speed imaging and advanced photon counting camera systems.

Our continuing success is built upon continuous innovation and product development, and by harnessing and applying knowledge to find solutions for all of our customers' applications.

Photek is accredited to ISO 9001 and ISO 14001.



Contact Us

Our team of specialist engineers and scientists are ready to discuss your application requirements in depth.

T: +44 (0)1424 850 555

E: sales@photek.co.uk

Photek Ltd reserves the right to update and improve this document without prior notice.